

Soft Absorber

FA-3650UD/FWM-3650UBD Series

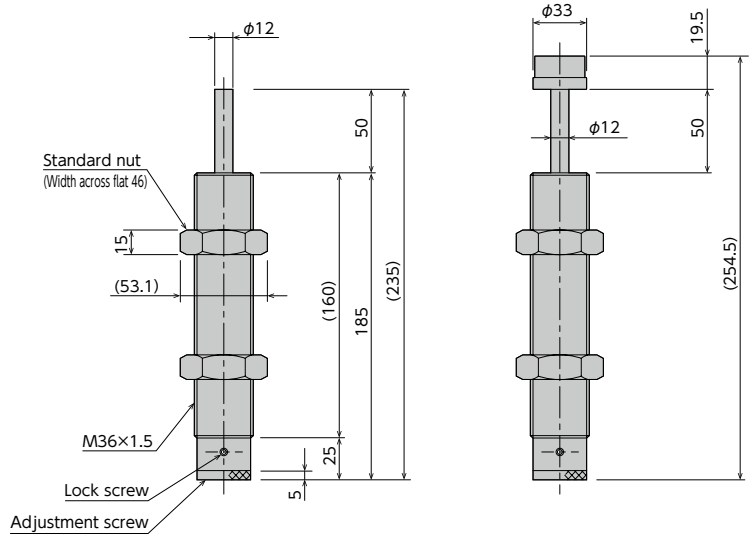

Specifications

Model	Stroke mm	Max. absorption energy J (kgf·m)	Max. equivalent mass kg (kgf)	Range of impact rate m/s	Orifice type
FA-3650UD-S	50	392 (40)	1,400 (1,400)	0.7~3	Single-orifice type
FA-3650UD-C					
FWM-3650UBD-S			2,700 (2,700)	0.3~2	Multiple-varying orifice type
FWM-3650UBD-C					

Note) To place an order without a cap, put -S at the end of the model number, and to place an order with a cap, put -C at the end of the model number.

Common Specifications

Max. drag	N (kgf)	23,520 (2,400)	Operating temperature	°C	-5~70
Max. cycle rate	cycle/min	30	Mass : S type	g	1,330
Max. absorption energy per minute	J/min (kgf·m/min)	2,352 (240)	: C type	g	1,410
Recovering power of the piston rod	N (kgf)	68.6 (7.0) or lower			

Selection Guideline

FA-3650 series has the following three patterns of absorption characteristics depending on the orifice type. Please use the following information as a guideline when making your selection.

Orifice type	Multiple-orifice type	Multiple-varying orifice type
Model number	FA-3650UD series	FWM-3650UBD series
Application	For high-speed	For medium speed, in particular with a pneumatic cylinder
Absorption characteristics		

Precautions for Use

- * Do not use this product without carefully reading the attached owner's manual.
- * Ensure that an external stopper (Stopper nut OP-020UB) is also used.
- * Do not turn the oil inlet screw located at the bottom of the main unit.
- * Ensure that sufficient mounting strength is secured for this product. (As a guideline, it should be 2 to 3 times the maximum drag listed in the catalogue.)
- * Do not use this product in a vacuum or a location where it may come in contact with oil.
- * Ensure that an eccentric load is not applied to the soft absorber (Allowable eccentric angle: within $\pm 2.5^\circ$)

Adjustment Method

- To adjust, turn the adjustment knob located at the bottom of the main unit.
- * Because the adjustment can be done in an analog manner, a value between two integers on the indicator can be set.
 - * Once the adjustment is complete, secure with a lock screw using a hex wrench.

●Products specification might be changed without notice.

Optional Parts

Eccentric angle adaptor OP-010UB

Model
OP-010UB

- Screw the eccentric angle adaptor into the main unit until the cap for the eccentric angle and the piston rod form a tight connection. While maintaining this position, fasten the main unit's nut until secured.
- Use the eccentric angle adaptor when the eccentric angle is 2.5° or larger.
- The main unit can also be used as a stopper.
- Use it with a capless soft absorber.
- The maximum operating eccentric angle with an eccentric angle adaptor is ±10°.
- The caps and the guides for inclined use are not unbundled.

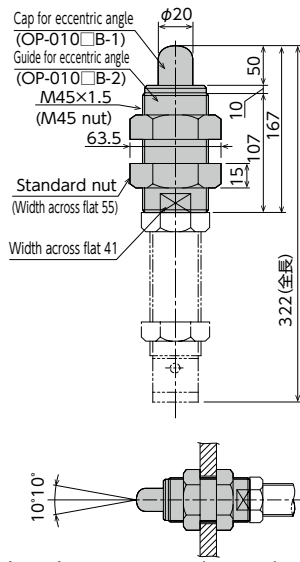

Mass 1,273g

Note) Material of cap for eccentric angle: Metal

Square flange OP-040UB

Model
OP-040UB

- Once the attachment site is determined, use the main unit's nut to securely fasten in place.

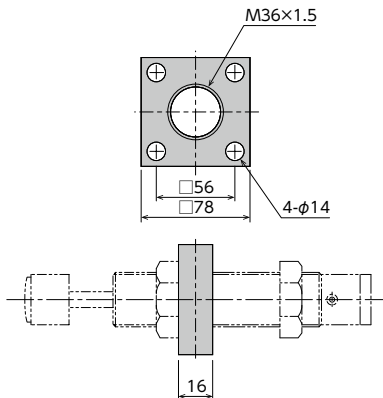

Mass 566g

Stopper nut OP-020UB-□

Model
OP-020UB-S
OP-020UB-C

- Adjust so that it stops 1mm before the stroke end, and fasten with the main unit's nut until secured.

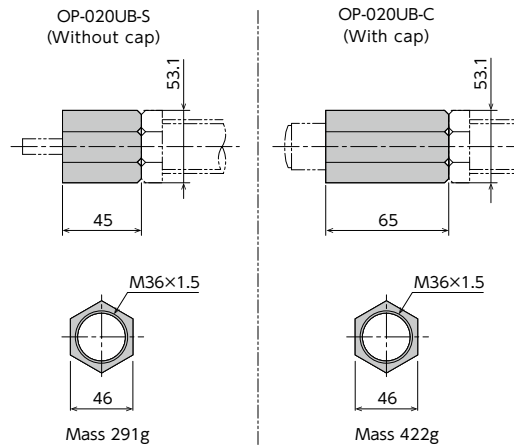

Note) When attaching, make sure that the side without a bearing chamfer is the impact surface.

Standard nuts are sold separately as well.

Applicable Models	Model
FA-3650UD	M36 nut
FWM-3650UBD	